



3527 (&7,21 \$,\*167 &25526,21

Hot dip galvanising according to CSA-G164 and ASTM A153 Standards.

67 \$1' \$5'S

All fittings are manufactured according to IEC 61284 Standard. Fasteners: galvanised steel as per ASTM A325 and ASTM A563 standards. Forged material: as per EN-10083 equivalent to ASTM A576 standard. Steel plates: EN-10025 equivalent to ASTM A36 or ASTM A572 standards. Locking pins: Stainless steel as per AISI 304.

# CLEVIS EYE EXTENSION LINKS

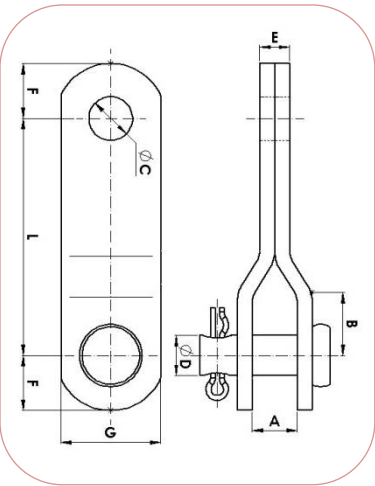

**Material:** Steel plate EN-10025 equivalent to ASTM A36 or ASTM A572.  
**Steel parts finish:** Hot dip galvanising ASTM A153.

**Bolt:** ASTM A325.  
**Nut:** ASTM A563.

Reference	Dimensions (inch)								Ultimate Strength (lb)	Weight (lb)
	A	B	C	D	E	F	G	L		
AL-8/95/AM	0.71	1.02	11/16	5/8	0.47	0.87	1.57	3.74	19,000	1.21
AL-8/140/AM	0.71	1.02	11/16	5/8	0.47	0.87	1.57	5.51	19,000	1.59
AL-8/200/AM	0.71	1.02	11/16	5/8	0.47	0.87	1.57	7.87	19,000	2.07

NOTE: Other dimension "C" can be manufactured upon request.  
 Special fasteners upon request.

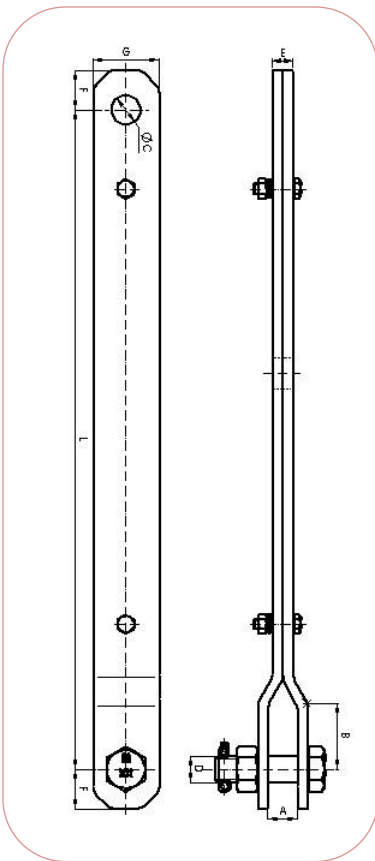

**Material:** Steel plate EN-10025 equivalent to ASTM A36 or ASTM A572.  
**Steel parts finish:** Hot dip galvanising ASTM A153.

**Bolt:** ASTM A325.  
**Nut:** ASTM A563.

Reference	Dimensions (inch)								Ultimate Strength (lb)	Weight (lb)
	A	B	C	D	E	F	G	L		
AL-12/300/AM	0.71	1.02	11/16	5/8	0.63	0.87	1.57	11.81	28,000	4.03
AL-12/400/AM	0.71	1.02	11/16	5/8	0.63	0.87	1.57	15.75	28,000	5.14
AL-12/650/AM	0.71	1.02	11/16	5/8	0.63	0.87	1.57	25.59	28,000	7.89
AL-12/800/AM	0.71	1.02	11/16	5/8	0.63	0.87	1.57	31.50	28,000	9.55
PF-150/AM	0.87	1.97	15/16	7/8	0.63	1.18	1.97	11.81	34,000	5.58
PF-150/600/AM	0.87	1.97	15/16	7/8	0.63	1.18	1.97	23.62	34,000	9.70
PF-150/900/AM	0.87	1.97	15/16	7/8	0.63	1.18	1.97	35.43	34,000	13.85
PF-300/AM	0.87	1.77	15/16	7/8	0.79	1.57	2.76	11.81	68,000	9.48
PF-300/600/AM	0.87	1.77	15/16	7/8	0.79	1.57	2.76	23.62	68,000	16.71
PF-300/900/AM	0.87	1.77	15/16	7/8	0.79	1.57	2.76	35.43	68,000	23.90

NOTE: Other dimension "C" can be manufactured upon request.  
 Special fasteners upon request.



## CLEVIS EYE EXTENSION LINKS

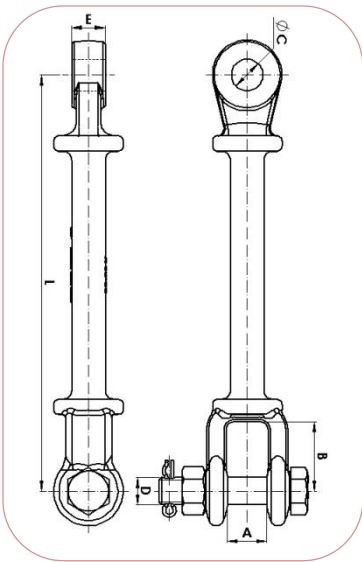

**Material:** Forged steel EN-10083 equivalent to ASTM A576.  
**Steel parts finish:** Hot dip galvanising ASTM A153.

**Bolt:** ASTM A325.  
**Nut:** ASTM A563.

Reference	Dimensions (inch)						Ultimate Strength (lb)	Weight (lb)
	A	B	C	D	E	L		
A-12/AM	0.98	1.77	11/16	5/8	0.87	10.63	30,000	3.53
A-18/AM	0.98	1.77	13/16	3/4	0.87	10.63	40,000	3.66
A-25/AM	0.98	1.77	15/16	7/8	0.87	10.63	56,000	3.75

NOTE: Other dimensions "E" and "C" can be manufactured upon request.  
 Special fasteners upon request.



## EYE EYE EXTENSION LINKS

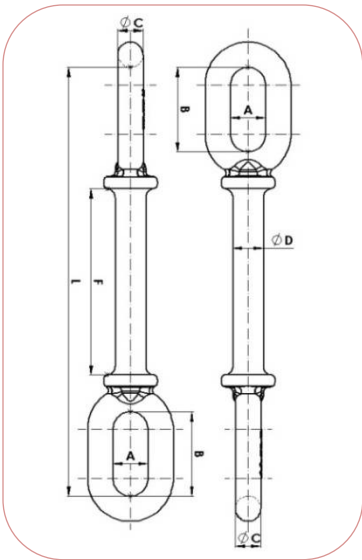

**Material:** Forged steel EN-10083 equivalent to ASTM A576.  
**Steel parts finish:** Hot dip galvanising ASTM A153.

Reference	Dimensions (inch)						Ultimate Strength (lb)	Weight (lb)
	A	B	C	D	F	L		
AA-24-R/AM	0.98	2.36	0.71	0.87	5.24	12.01	54,000	3.09



## DOUBLE EXTENSION LINKS

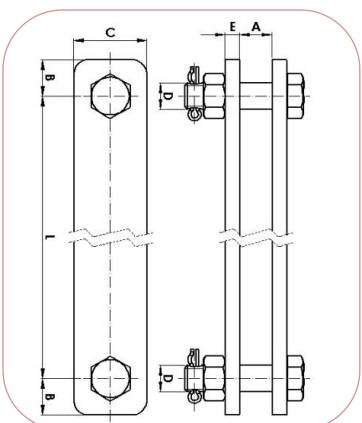

**Material:** Steel plate EN-10025 equivalent to ASTM A36 or ASTM A572.  
**Steel parts finish:** Hot dip galvanising ASTM A153.

**Bolt:** ASTM A325.  
**Nut:** ASTM A563.

Reference	Dimensions (inch)						Ultimate Strength (lb)	Weight (lb)
	A	B	C	D	E	L		
ALD-1/L/AM	0.79-1.02	0.83	1.57	5/8	0.31	L	28,000	-
ALD-2/L/AM	0.87-0.91	0.98	1.97	3/4	0.39	L	48,000	-
ALD-3/L/AM	0.94-0.98	1.18	2.36	7/8	0.39	L	54,000	-
ALD-4/L/AM	1.10-1.34	1.38	2.76	1	0.39	L	80,000	-
ALD-5/L/AM	1.18-1.34	1.57	2.76	1 1/4	0.59	L	110,000	-

NOTE: Dimension "L" upon request.  
 Special fasteners upon request.

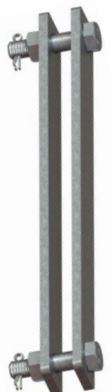

## SINGLE EXTENSION LINKS

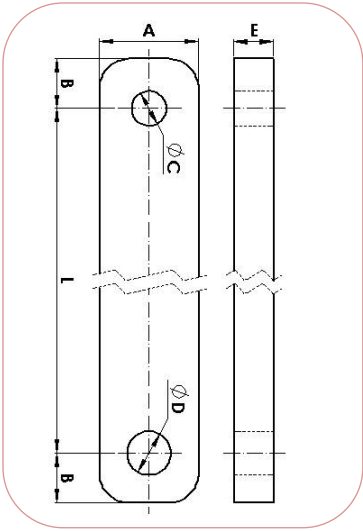

**Material:** Steel plate EN-10025 equivalent to ASTM A36 or ASTM A572.  
**Steel parts finish:** Hot dip galvanising ASTM A153.

Reference	Dimensions (inch)						Ultimate Strength (lb)	Weight (lb)
	A	B	C	D	E	L		
TA-1/L/AM	1.57	0.83	11/16	11/16	0.59	L	28,000	-
TA-2/L/AM	1.97	0.98	13/16	13/16	0.79	L	48,000	-
TA-3/L/AM	2.36	1.38	15/16	15/16	0.79	L	54,000	-
TA-4/L/AM	2.36	1.57	1 1/16	1 1/16	0.98	L	80,000	-
TA-5/L/AM	2.76	1.57	1 1/4	1 1/4	0.98	L	110,000	-

NOTE: Dimension "L" upon request.



## BIRD PREVENTION EXTENSION LINKS

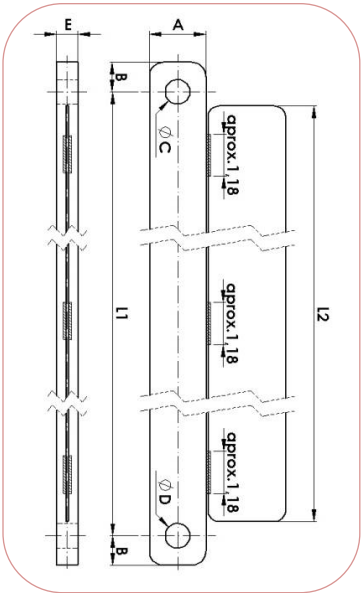

**Material:** Steel plate EN-10025 equivalent to ASTM A36 or ASTM A572.  
**Steel parts finish:** Hot dip galvanising ASTM A153.

Reference	Dimensions (inch)							Ultimate Strength (lb)	Weight (lb)
	A	B	C	D	E	L1	L2		
TA-1/470-AV/AM	1.57	0.83	11/16	11/16	0.59	18.50	17.72	30,000	5.95
TA-1/590-AV/AM	1.57	0.83	11/16	11/16	0.59	23.23	22.44	30,000	7.50

NOTE: Other dimension "L" can be manufactured upon request



## SAG ADJUSTER LINKS

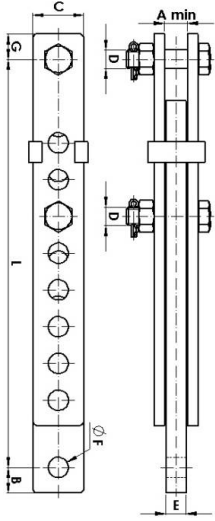

**Material:** Steel plate EN-10025 equivalent to ASTM A36 or ASTM A572.  
**Steel parts finish:** Hot dip galvanising ASTM A153.

**Bolt:** ASTM A325.  
**Nut:** ASTM A563.

Reference	Dimensions (inch)								Ultimate Strength (lb)	Weight (lb)	
	A	B	C	D	E	F	G	L			
								Min			Max
T-1/AM	0.59	0.96	1.57	5/8	0.59	11/16	0.87	12.60	19.69	28,000	6.66
T-2/AM	0.79	0.98	1.97	3/4	0.79	13/16	0.98	15.55	24.61	48,000	12.83
T-3/AM	0.79	1.26	2.36	7/8	0.79	15/16	1.06	20.67	34.45	54,000	20.04
T-4/AM	0.98	1.57	2.36	1	0.98	1 1/16	1.38	21.02	34.17	80,000	25.75

NOTE: Other dimension "F" can be manufactured upon request.  
 Special fasteners upon request.



## TURNBUCKLES



**Material:** Forged steel EN-10083 equivalent to ASTM A576.  
**Steel parts finish:** Hot dip galvanising ASTM A153.

**Nut:** ASTM A563.

Reference	Dimensions (inch)				Ultimate Strength (lb)	Weight (lb)
	C	E	L			
			Min	Max		
TR-16/OO/AM	0.71	11/16	18.11	26.18	28,000	6.33
TR-20/OO/AM	0.71	13/16	18.11	26.18	36,000	6.28

NOTE: Other dimension "E" can be manufactured upon request.



# TURNBUCKLES

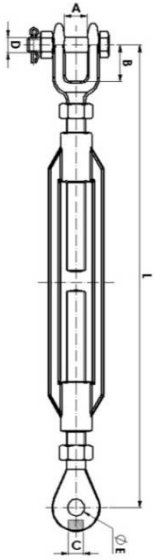

**Material:** Forged steel EN-10083 equivalent to ASTM A576.  
**Steel parts finish:** Hot dip galvanising ASTM A153.

**Bolt:** ASTM A325.  
**Nut:** ASTM A563.

Reference	Dimensions (inch)							Ultimate Strength (lb)	Weight (lb)
	A	B	C	D	E	L			
						Min	Max		
TR-16/OH/AM	0.91	1.50	0.71	5/8	11/16	18.31	26.38	28,000	6.99
TR-20/OH/AM	0.91	1.50	0.71	3/4	13/16	18.31	26.38	36,000	7.10

NOTE: Other dimension "E" can be manufactured upon request.  
 Special fasteners upon request.

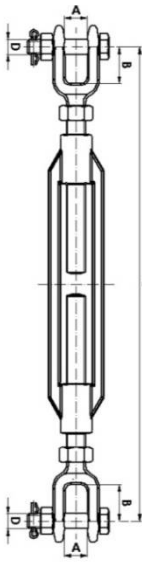

**Material:** Forged steel EN-10083 equivalent to ASTM A576.  
**Steel parts finish:** Hot dip galvanising ASTM A153.

**Bolt:** ASTM A325.  
**Nut:** ASTM A563.

Reference	Dimensions (inch)					Ultimate Strength (lb)	Weight (lb)
	A	B	D	L			
				Min	Max		
TR-16/HH/AM	0.91	1.50	5/8	18.50	26.57	28,000	7.67
TR-20/HH/AM	0.91	1.50	3/4	18.50	26.57	36,000	7.94

NOTE: Special fasteners upon request.

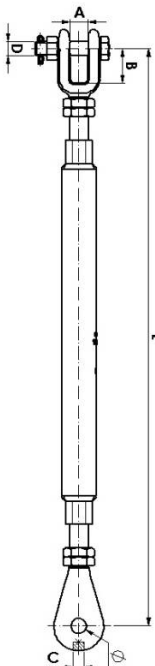

**Material:** Forged steel EN-10083 equivalent to ASTM A576.  
**Steel parts finish:** Hot dip galvanising ASTM A153.

**Bolt:** ASTM A325.  
**Nut:** ASTM A563.

Reference	Dimensions (inch)						Ultimate Strength (lb)	Weight (lb)	
	A	B	C	D	E	L			
						Min			Max
TRB-24/OH/AM	0.87	1.77	0.79	7/8	15/16	26.97	42.52	56,000	15.76
TRB-24/OH/C/AM	0.87	1.77	0.79	7/8	15/16	17.32	22.64	56,000	10.03

NOTE: Other dimension "E" can be manufactured upon request.  
 Special fasteners upon request.

